

CERAMIC FINE FILTER FF

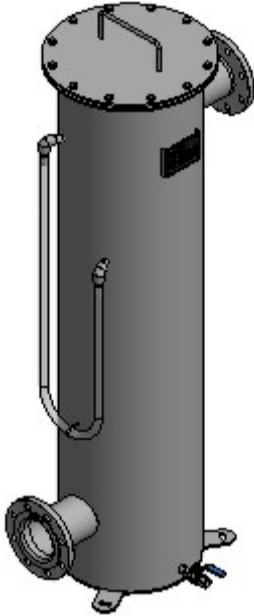

- Separation of ultrafine particles and humidity from biogas/sewage gas
 - Fine purification of the gas, e.g., directly before gas engines
 - Low pressure loss
 - Removable filter inserts for easy cleaning
 - Optional differential pressure gauging and condensate drainage
 - Entirely made from 1.4404 stainless steel
- Made in Austria

ENVIRONTEC'S CERAMIC FINE FILTER

Fine filters are used for the fine purification of sewage gas/biogas. This allows the separation of fine particles $\geq 8 \mu\text{m}$ as well as condensate vapour resulting in the availability of gas for further use that is free of foreign matter to the greatest possible extent.

EnvironTec fine filters are fitted with filter candles made from Pantel (special fire clay). As the gas flows through the filter candles from the outside to the inside foreign matter is separated out on the outer wall. The filter material used is chemically

resistant/neutral, has a high filtration performance coupled with a low pressure loss and is easy to clean with pressure washers.

Any condensate build-up can be drained via an optional siphon or condensate separator. If required, the fine filters can also be fitted with differential pressure gauging (U-tube or individual pressure gauges).

EnvironTec fine filters are entirely made from 1.4404 stainless steel.

APPLICATIONS AND SPECIFICATIONS

- Gas purification by removal of solid particles and condensate vapours
- Filtration rating: $\geq 8 \mu\text{m}$
- Optionally available with differential pressure gauging, water level indication and condensate drainage

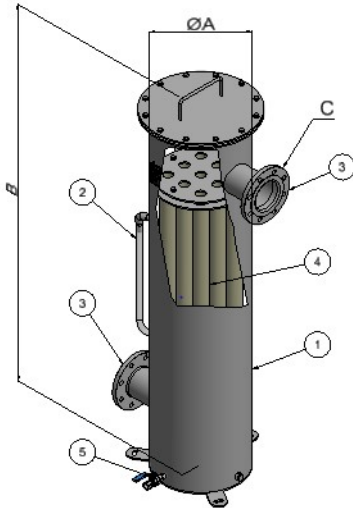

1. Fine particle filter - body
2. U-tube pressure gauge
(differential pressure gauging / optional)
3. Gas inlet / outlet
4. Ceramic filter candles
5. Connector for additional equipment
(condensate drain)

Model size	Diameter	Height	Flow rate	Gas connection
	ØA in mm	B in mm	Nm ³ /h	C in DN
FF 50	168,3	1.600	< 50	40
FF 75	168,3	1.600	50 - 75	50
FF 150	273	1.600	75 - 150	80
FF 250	356	1.600	150 - 250	100
FF 500	506	1.600	250 - 500	125
FF 750	606	1.600	500 - 750	150
FF 1.000	606	1.600	750 - 1.000	200

TYPE SPECIFICATION

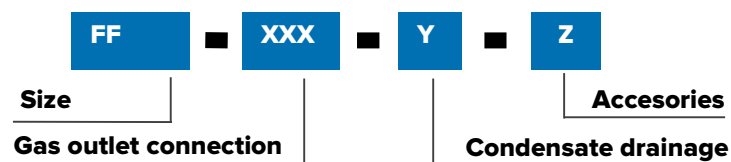

Y k__manual with ball valve
s__siphon
a__automatic condensate drain

Z u__differential gauging with U-tube pressure gauge
m__differential pressure gauging with pressure gauge